

**ΕΘΝΙΚΟ ΜΕΤΣΟΒΙΟ ΠΟΛΥΤΕΧΝΕΙΟ**

**ΣΧΟΛΗ ΗΛΕΚΤΡΟΛΟΓΩΝ ΜΗΧΑΝΙΚΩΝ ΚΑΙ ΜΗΧΑΝΙΚΩΝ  
ΥΠΟΛΟΓΙΣΤΩΝ**

**ΕΝΕΡΓΕΙΑ**

**INSTALLATION OF SOLAR ENERGY FOR HOMES (A typical  
Home in Freetown, Sierra Leone).**

**ΔΙΠΛΩΜΑΤΙΚΗ ΕΡΓΑΣΙΑ**

**GLENN-KAMARA IBRAHIM**

**Επιβλέπων : Μαρία Γ. Ιωαννίδου**

**Καθηγήτρια Ε.Μ.Π.**

**Αθήνα, Μάρτιος 2017**

**Εγκρίθηκε από την τριμελή εξεταστική επιτροπή:**

**Μαρία Γ. Ιωαννίδου Νικόλαος Θεοδώρου Παναγιώτης  
Τσαραμπάρης**

**Καθηγήτρια Ε.Μ.Π. Καθηγητής Ε.Μ.Π. Λέκτορας Ε.Μ.Π.**

**GLENN-KAMARA IBRAHIM**

**Electrical and Computer Engineer NTUA**

**Copyright ©**

**All rights reserved.**

**Copying, storage and distribution of this work, in whole or part of it, for commercial purposes. Reproduction, storage and distribution for the purpose of non-profit, educational or research nature, provided that the source of origin and to maintain the existing message. Questions concerning the use of labor for profit should be addressed to the author.**

**The views and conclusions contained in this document reflect the author and should not be interpreted as representing the official position of the National Technical University of Athens.**

## **PREFACE**

I would like to thank Professor Mrs. Maria G. Ioannidou (NTUA) for the excellent cooperation we had during the preparation of this thesis, for the confidence she had in me and for the opportunity offered to me to present such an interesting subject.

I would like to thank all my people who have supported and believed in me.

## Περίληψη

Ως Ηλεκτρολόγος Μηχανικός από το ΕΜΠ, ένα από τα προβλήματα (ανάγκες) που θέλω να λύσω στην χώρα μου είναι το πρόβλημα της ηλεκτρικής ενέργειας (ηλεκτροδότηση).

Αυτό είναι ένα πολύ σοβαρό πρόβλημα που αντιμετωπίζει η χώρα και σε μια μεγαλύτερη κλίμακα εμποδίζει την ανάπτυξη της χώρας με πολλούς τρόπους, ένας από τους πιο σοβαρή είναι η απομόνωση του από τον υπόλοιπο κόσμο σε αυτή την ψηφιακή εποχή.

Πολύ λίγοι άνθρωποι έχουν πρόσβαση σε αυτό το αγαθό και ως αποτέλεσμα τον περιορισμό της χρήσης των ψηφιακών συσκευών σε όλη τη χώρα. Επίσης, η ηλεκτρική ενέργεια είναι μια πολύ βασική ανάγκη που απαιτείται για την καθημερινή διαβίωση με αμέτρητες χρήσεις, όπως η λειτουργία της εγχώριας πρώτης ανάγκης (κουζίνες, πλυντήριο ρούχων, ελάφρυνση του σπιτιού, το σιδέρωμα και πολλά άλλα)

Είναι επίσης απαραίτητη σε νοσοκομεία και κλινικές, φαρμακεία, σχολεία, κυβερνητικά γραφεία, δημόσιους δρόμους, και της ζωής φυσικά χωρίς ηλεκτρικό ρεύμα είναι απλά καταστροφική. Αυτό δεν είναι μυστικό για κάθε πολίτη της Σιέρρα Λεόνε που ζουν στο εσωτερικό της χώρας ή σε όλο τον κόσμο, έτσι επομένως πολλές λύσεις τόσο σε κυβερνητικό όσο και του ιδιωτικού έχουν έρθει περίπου από την τελευταία δεκαετία. Δυστυχώς, δεν είναι όλα είναι ασφαλή, φιλικά προς το περιβάλλον, αξιόπιστο ή ακόμα και αποδοτικές.

Σε έναν κόσμο όπου ένας στους πέντε άνθρωποι ζουν χωρίς ηλεκτρικό ρεύμα, παροχή καθαρού, μετασχηματιστική ενέργειας για τα νοικοκυριά που πλήττονται από ακριβά, αναξιόπιστα δίκτυα ή δεν έχουν πρόσβαση στο δίκτυο καθόλου. Αυτή η καινοτομία είναι μη αποκλειστική, δηλαδή ο καθένας στα οφέλη των νοικοκυριών - άνδρες και γυναίκες, νέους και ηλικιωμένους. Το έργο αυτό θα ανάψει τα σπίτια πολλών ανθρώπων κάθε μήνα, και ο αριθμός αυτός θα αυξάνεται .

Με την παραγωγή ανανεώσιμης ενέργειας από τον ήλιο, το σύστημα αυτό θα βοηθήσει τους ανθρώπους να μειώσουν τις εκπομπές αερίων του θερμοκηπίου. Αντικατάσταση όλων των λαμπτήρων κηροζίνης σε εθνικό επίπεδο με ηλιακά φώτα θα είναι ισοδύναμη με μια σημαντική μείωση των ετήσιων εκπομπών. Κάθε νέο νοικοκυριό που θα επιτευχθεί σημαίνει ένα σημαντικό ποσό των εκπομπών διοξειδίου του άνθρακα ανά έτος να αποφεύγεται. Οι περισσότερες οικογένειες ζουν σε αγροτικές περιοχές εκτός δικτύου χρησιμοποιούν αμυδρό λάμπες κηροζίνης για να ανάψουν τα σπίτια τους τη νύχτα. Καύση του καυσίμου μέσα μολύνει τον αέρα με επιβλαβή σωματίδια, τα οποία μπορεί να ερεθίσουν τα μάτια και τους πνεύμονες, και βάζει τα παιδιά σε κίνδυνο κατά λάθος καίει τον εαυτό τους. Μετατοπίζοντας χρήση κηροζίνης με ισχυρά LEDs μας, όχι μόνο να μειώσει αυτές τις επικίνδυνες παρενέργειες, αλλά παρέχουν το φως που ολόκληρη η οικογένεια μπορεί να απολαύσει ταυτόχρονα. Αυτό επεκτείνει το δυναμικό χρόνο για τη μελέτη ή άλλες παραγωγικές δραστηριότητες.

Η οικονομική προσιτότητα αυτού του συστήματος επιτρέπει στους ανθρώπους να διατηρήσουν την τρέχουσα ενεργειακή δαπάνες τους, ενώ να πάρει φωτεινότερο φως και πιο ισχυρό ηλεκτρονικών ειδών. Ιδιαίτερα με υψηλής ποιότητας συσκευές όπως ραδιόφωνα και τηλεοράσεις, αυτή η ηλιακή λύση μπορεί να επιτρέψει σημαντική εξοικονόμηση κόστους για τα σπίτια. το εισόδημα των νοικοκυριών μπορεί επίσης να αυξηθεί, σε πολλές περιπτώσεις, γιατί οι άνθρωποι θα είναι σε θέση να κρατήσουν τα μαγαζιά τους ανοιχτά πλέον ή χρησιμοποιούν τις νυχτερινές ώρες και για άλλες δραστηριότητες που παράγουν εισόδημα.

Κατά την επόμενη δεκαετία, ο τομέας των ανανεώσιμων πηγών ενέργειας θα γίνει ένας από τους μεγαλύτερους εργοδότες στην Αφρική. Παρόμοια έργα όπως αυτό θα δημιουργήσει πολλές νέες θέσεις εργασίας κάθε μήνα μέσω των διαδικασιών πρόσληψης και κατάρτισης. Θα παρέχει επίσης οικονομική ευκαιρία σε ένα πρόθυμο και ταλαντούχους τοπικού εργατικού δυναμικού, σε ένα γρήγορο εκκίνηση περιβάλλον.

## Λεξεις Κλειδια

Εγκατάσταση ηλιακής ενέργειας για σπίτια

## Summary

As an Electrical Engineer from NTUA, one of the problems (needs) that I want to solve my country is the problem of electrical energy (electricity).

This is a very serious problem facing the country and on a larger scale hinders the country's development in many ways, one of the most severe isolation from the outside world in this digital age.

Very few people have access to this object and effect of restricting the use of digital devices throughout the country. Also, electricity is a basic need that is required for daily living with countless uses, such as the functioning of domestic necessities (kitchen, washing machine, lightening the house, ironing and much more)

It is also required in hospitals and clinics, pharmacies, schools, government offices, public roads, and of course life without electricity is simply catastrophic. This is no secret to every citizen of Sierra Leone living in the country or around the world, so therefore many solutions both governmental and private have come about since the last decade. Unfortunately, not all is safe, environmentally friendly, reliable or even profitable.

In a world where one in five people live without electricity, providing clean, transformative energy for households affected by expensive, unreliable networks or have no network access at all. This innovation is not exclusive, that everyone in the household benefits - men and women, young and old.



This work of many people's homes will illuminate every month, and this number will grow. With the production of renewable energy from the sun, this system will help people to reduce their greenhouse gas emissions. Replace all kerosene lamps nationwide with solar lights is equivalent to a significant reduction of annual emissions. Each new household that will be achieved means a significant amount of carbon dioxide emissions per year avoided. Most families live in rural off-grid using dim kerosene lamps to light their homes at night. Burning fuel in polluting the air with harmful particles that can irritate the eyes and lungs, and puts children at risk of accidentally burning themselves. Displacing kerosene with our powerful LEDs, not only to reduce these dangerous side effects, but provide light that the whole family can enjoy together. This extends the potential time for study or other productive activities.

The affordability of this system allows people to maintain their current energy costs, while getting brighter light and more powerful electronics. Especially with high-quality appliances such as radios and televisions, this solar solution can enable significant cost savings for homes. Household income may also increase, in many cases, because people will be able to keep their shops open longer or use the night hours and other income generating activities.

Over the next decade, the sector of renewable energy sources will become one of the largest employers in Africa. Similar projects like this will create many new jobs every month through recruitment and training procedures. It will also provide economic opportunity to an eager and talented local workforce, at a fast startup environment.

## **Key Words**

Installation of Solar Energy for Homes

## **Installation of Solar Energy for Homes**

### **(A typical home in Freetown, Sierra Leone)**

My name is Ibrahim and I am from Sierra Leone which is situated on the West Coast of the African continent. It is a third-world country with a population of over six million people, 80% of which survive on a daily base under conditions lower than the average required for any human being on the planet.

Based on the fact that it is a third world country and the nation has been destroyed by a ten year civil war (1990-2000) with very devastating effects on politics, infrastructure and many more, there are a lot of problems and challenges that the citizens of our country face day by day.

Despite the country has been richly blessed with a lot of mineral resources, some of which are gold, silver, very valuable diamonds, copper, agriculture, beautiful beaches and exotic destinations for tourism, fishery and many more, sadly the country has been listed as one of the poorest in the world.

However, due to the recent developments in the economy, the widespread of education across the nation to the current generation, the country has experienced tremendous development in many areas, some of which are infrastructure i.e building and road construction, an increase in the value of the currency (Leones), a general development of the economy as a whole by the provision of more job opportunities, an increase in the standard of living (better schools, better health care and sanitation), improvement in the quality of government services (ministries), and in so many other areas.

Despite all this development, the country still faces many fundamental problems, some of which are: lack of electricity, low level of medical facilities (when compared to the required level) which leads to lower life expectancy and higher infant mortality, lack of maintenance of

governmental facilities, mismanagement of government funds, a high level of corruption, poor human sensitization and many more.

As an Electrical Engineer from the NTUA, one of the problems (needs) that I wish to tackle is the problem of electricity (electrification).

This is a very serious problem that the country is facing and on a bigger scale is hindering the development of the country in many ways, one of the most serious being its isolation from the rest of the world in this Digital Age.

Very few people have access to this commodity and as a result limit the use of digital devices throughout the country. Also electricity is a very basic necessity that is required for daily living with countless uses like the operation of domestic essentials (cookers, washing machine, lightening of the home, ironing and a lot more)

It is also needed in hospitals and clinics, pharmacies, schools, government offices, public roads, and of course life without electricity is just devastating. This is no secret to every citizen of Sierra Leone living within the country or around the world, so therefore a lot of



solutions both governmental and private have come about since the last decade. Unfortunately, not all are safe, environmentally friendly, reliable or even cost effective.

Some solutions include the use of petrol or diesel generators for homes, very expensive power plants that only very few people can afford, the use of rechargeable domestic appliances and more, but however a new trend has been introduced by a lot of new companies which the Use of Solar Energy.

Since the technology is new it is expensive and most people cannot afford it, however because so many companies are investing in this sector Solar Energy is the future because eventually it will be more affordable, safer, environmentally friendly and above all, reliable.

In this diploma thesis I will outline the energy study of how I intend to solve and provide the energy needs for a typical home in Freetown which is the capital without using the network of the National power Authority (NPA).

Starting off, I will analyze the whole natural background which is behind the mode of the solar panel, that is the photovoltaic phenomenon and how we could take advantage of it to get electrical energy.

## **CONTENTS**

### **CHAPTER 1 Introduction to Solar Energy**

1.1 What is Solar Energy.....	11
1.2 The 3 basic types of Solar panels.....	12
1.3 Shading & Shadows on solar panels.....	13
1.4 Types of Solar Panel Array Mountings : Fixed, Adjustable,&Tracking .....	14
1.5 How much sunshine will I need? .....	15
1.6 Cost and expected Life-Span of solar panels.....	16

1.7 Source.....	17
1.8 Two main types of solar energy systems are in use today: photovoltaics, and thermal systems.....	17
1.9 Why is solar energy important.....	21
1.10 Why Solar Power is a Reliable Long Term Investment....	21
1.11 Sunlight is Free and has Guaranteed Long-Term Availability.....	22
1.12 What are the benefits of solar energy.....	23
1.13 Advantages of Solar.....	23
1.14 Solar Cell with Clouds Disadvantages of Solar.....	23

## **Chapter 2: Equipment, Installation and Maintenance**

2.1 Charge Controllers.....	25
2.2 Modern multi-stage charge controllers.....	25
2.3 General Recommendations.....	26
2.4 Materials recommendations.....	27
2.5 Equipment recommendations and installation methods...	27
2.6 PV System Design And Installation.....	29
2.7 Design Phase.....	30
2.8 Installation Phase.....	32
2.9 Maintenance and Operation Phase.....	37

2.10 SOLAR ELECTRIC (PV) SYSTEM INSTALLATION CHECKLIST	37
2.11 PV ARRAY CIRCUIT WIRING (hard hat and eye protection recommended)	39
2.12 REPETITIVE SOURCE CIRCUIT STRING WIRING (hard hat, gloves, and eye protection recommended)	39
2.13 CONTINUATION OF PV ARRAY CIRCUIT WIRING (hard hat, gloves, and eye protection recommended)	40
2.14 WIRING TESTS--Remainder of System: (hard hat, gloves, and eye protection recommended)	40
2.15 INVERTER STARTUP TESTS (hard hat, gloves, and eye protection recommended)	41
2.16 SYSTEM ACCEPTANCE TEST (hard hat and eye protection recommended)	42

**Chapter 3: Consumption**

3.1 Power consumption Table	45
3.2 THE ECONOMICS OF A SMALL SOLAR ELECTRIC SYSTEM	47
3.3 ELECTRICITY CONSUMPTION	48
3.4 PV COST CONSIDERATIONS	48
3.5 PERMITS AND COVENANTS	49
3.6 STAND-ALONE SMALL SOLAR ELECTRIC SYSTEMS	50

**Chapter 4: Self-consumption and Summary**.....53



4.1 Natural: Self-consumption.....	54
4.2 Optimized Self-Consumption, Generation Consumption....	55
4.3 Self-consumption pays off! .....	56
4.4 A Brief Summary.....	57

## **Chapter 5**

5.1 Conclusion.....	60
5.2 Περίληψη.....	61

## **Chapter 1**

### **1.1 What is solar energy?**

According to the Environment Protection Agency, solar energy is defined as energy derived from the sun's radiation. Solar energy sustains life on earth. It is also becoming increasingly common that this energy is converted and used as an alternative to fossil fuels.

Solar energy is radiant light and heat from the Sun that is harnessed using a range of ever-evolving technologies such as solar heating, photovoltaics, solar thermal energy, solar architecture, molten salt power plants and artificial photosynthesis.

Solar panels generate free power from the sun by converting sunlight to electricity with no moving parts, zero emissions, and no maintenance.

The solar panel, the first component of an electric solar power system, is a collection of individual silicon cells that generate electricity from

sunlight. The photons (light particles) produce an electrical current as they strike the surface of the thin silicon wafers.

A single solar cell produces only about 1/2 (.5) of a volt. However, a typical 12 volt panel about 25 inches by 54 inches will contain 36 cells wired in series to produce about 17 volts peak output. If the solar panel can be configured for 24 volt output, there will be 72 cells so the two 12 volt groups of 36 each can be wired in series, usually with a jumper, allowing the solar panel to output 24 volts. When under load (charging batteries for example), this voltage drops to 12 to 14 volts (for a 12 volt configuration) resulting in 75 to 100 watts for a panel of this size.

Multiple solar panels can be wired in parallel to increase current capacity (more power) and wired in series to increase voltage for 24, 48, or even higher voltage systems. The advantage of using a higher voltage output at the solar panels is that smaller wire sizes can be used to transfer the electric power from the solar panel array to the charge controller & batteries. Since copper has gone up considerably in the last few years, purchasing large copper wiring and cables is quite expensive. (that's why pennies are made of mostly zinc today).

## **1.2 The 3 basic types of Solar Panels**



**Monocrystalline solar panels** : The most efficient (15 – 20%) and expensive solar panels are made with. Monocrystalline cells - these solar

cells use very pure silicon and involve a complicated crystal growth process. Long silicon rods are produced which are cut into slices of .2 to .4 mm thick discs or wafers which are then processed into individual cells that are wired together in the solar panel.

**Polycrystalline solar panels** : Often called Multi-crystalline, solar panels made with Polycrystalline cells are a little less expensive & slightly less efficient than Monocrystalline cells because the cells are not grown in single crystals but in a large block of many crystals. This is what gives them that striking shattered glass appearance. Like Monocrystalline cells, they are also then sliced into wafers to produce 12 the individual cells that make up the solar panel.

**Amorphous solar panels** : These are not really crystals, but a thin layer of silicon deposited on a base material such as metal or glass to create the solar panel. These Amorphous solar panels are much cheaper, but their energy efficiency is also much less so more square footage is required to produce the same amount of power as the Monocrystalline or Polycrystalline type of solar panel. Amorphous solar panels can even be made into long sheets of roofing material to cover large areas of a south facing roof surface.

### **1.3 Shading & Shadows on solar panels**

When deciding on a location for your solar panels, make sure no shadows will fall on the solar panel array during peak sunlight hours (say, 9am to 4pm). Not only could shading of the solar panels significantly reduce their output, but also could cause damage. Many solar panel manufacturers advertise panels that can withstand shading but they use internal diodes (by-pass diodes) which in themselves reduce the power somewhat. Best to choose a good location to start

with, even if it means cutting down a few trees or otherwise removing obstacles. Temperature & Wind loading considerations

As previously discussed, you want to mount solar panels in a sunny and non-shaded location to get maximum sun. But, heat build-up is also a problem. Because the efficiency of solar panels decreases as temperature increases, the solar panel mounting system should allow for spacing around the individual solar panels for air circulation. The idea is to allow air cooling in the hot sun to reduce the temperature of the solar panels. Another consideration is wind loading. By allowing air to flow around the solar panels, not only will they remain cooler, but also the wind resistance of the entire array is less.

#### **1.4 Types of Solar Panel Array Mountings : Fixed, Adjustable, & Tracking**

Fixed Solar Panel Mounts: If you use the most simple and least expensive type of solar panel mounting system, it will be completely stationary.

The solar panels should always face the equator. (due south in the northern hemisphere). Don't forget that true south varies from magnetic south.

This can make a huge difference. For example, true south in eastern Washington state is 161 on a compass instead of 180. The angle of inclination (tilt) in degrees should be set to about your latitude. Slightly more than your latitude will favor the winter sun and slightly less will favor the summer sun. (for a seasonal cabin for example).

**Adjustable solar panel mounts :**



The angle of inclination (tilt) of an adjustable solar panel mount can be changed 2 or more times during the year to account for the lower angle of the sun in winter as the earth orbits the sun causing seasonal change.

A good rule of thumb is latitude + 15 degrees in the winter and latitude - 15 degrees in the summer. This will increase overall solar panel output by approximately 25%. I adjust my solar panel array 4 times per year. (Shown here in its summer position). An easy approach that works pretty good is to set the tilt for the winter position in about mid October and back to summer position in mid March.

### **Tracking solar panel mounts :**

Tracking solar panel mounts follow the path of the sun during the day to maximize the solar radiation that the solar panels receive. A single axis tracker tracks the sun east to west and a two-axis tracker tracks the daily east to west movement of the sun and the seasonal declination movement of the sun.

I must admit that a tracking type of solar panel mount is the most efficient type. However, when I investigated the cost for these mounting systems, I found that for the 20 to 30 percent gain in output they provided I could buy 25% more panels cheaper and have the same

increase in power with no mechanical failures to worry about. Also, you'll get far less extra gain in winter assuming it doesn't freeze up!

Therefore, I recommend that instead of 6 panels on a tracking mount that costs \$2000-\$3000, just spend \$700-\$800 on 2 more solar panels and gain a year round increase of 25 to 30%.

### **1.5 How much sunshine will I need?**

For more detailed information on how many solar panels you will need based on the amount of sunshine available daily in your area (of West Africa) please check out the Solar Radiation chart . This will give you a better idea of how many solar panels you will need for your solar power system.

### **1.6 Cost and expected Life-Span of solar panels**

At today's prices a single solar panel, rated at 250 watts sells for about \$350-\$425 depending on brand. I have found that the brand does not seem to be a huge factor. If your system uses many of these panels, this would seem to be a big investment. The good news is that today's solar panels have a life expectancy of 25 to 30 years or more. And just think, they'll be making FREE electricity that whole time!

It is an important source of renewable energy and its technologies are broadly characterized as either passive solar or active solar depending on how they capture and distribute solar energy or convert it into solar power. Active solar techniques include the use of photovoltaic systems, concentrated solar power and solar water heating to harness the energy. Passive solar techniques include orienting a building to the Sun, selecting materials with favorable thermal mass or light-dispersing properties, and designing spaces that naturally circulate air.

The large magnitude of solar energy available makes it a highly appealing source of electricity. The United Nations Development Programme in its 2000 World Energy Assessment found that the annual potential of solar energy was 1,575–49,837 exajoules (EJ). This is several times larger than the total world energy consumption, which was 559.8 EJ in 2012.

In 2011, the International Energy Agency said that "the development of affordable, inexhaustible and clean solar energy technologies will have huge longer-term benefits. It will increase countries' energy security through reliance on an indigenous, inexhaustible and mostly import-independent resource, enhance sustainability, reduce pollution, lower the costs of mitigating global warming, and keep fossil fuel prices lower than otherwise. These advantages are global. Hence the additional costs of the incentives for early deployment should be considered learning investments; they must be wisely spent and need to be widely shared".

Solar energy can be harnessed using a range of technologies such as solar photovoltaic, solar heaters and solar thermal electricity. It is considered an environmentally friendly source of energy because it comes directly from the sun; it does not involve the burning of fossil fuels. The primary limitation of solar energy is that it is not always available, and methods of storage and stop-gap are required for when it is cloudy or raining outside.

### **1.7 Source.**

The sun is probably the most important source of renewable energy available today

Traditionally, the sun has provided energy for practically all living creatures on earth, through the process of photosynthesis, in which plants absorb solar radiation and convert it into stored energy for

growth and development. Scientists and engineers today seek to utilize solar radiation directly by converting it into useful heat or electricity.

**1.8 Two main types of solar energy systems are in use today: photovoltaics, and thermal systems.**

The Earth receives 174,000 terawatts (TW) of incoming solar radiation (insolation) at the upper atmosphere.[5] Approximately 30% is reflected back to space while the rest is absorbed by clouds, oceans and land masses. The spectrum of solar light at the Earth's surface is mostly spread across the visible and near-infrared ranges with a small part in the near-ultraviolet.[6] Most of the world's population live in areas with insolation levels of 150-300 watts/m<sup>2</sup>, or 3.5-7.0 kWh/m<sup>2</sup> per day.[citation needed]

Solar radiation is absorbed by the Earth's land surface, oceans – which cover about 71% of the globe – and atmosphere. Warm air containing evaporated water from the oceans rises, causing atmospheric circulation or convection. When the air reaches a high altitude, where the temperature is low, water vapor condenses into clouds, which rain onto the Earth's surface, completing the water cycle. The latent heat of water condensation amplifies convection, producing atmospheric phenomena such as wind, cyclones and anti-cyclones.[7] Sunlight absorbed by the oceans and land masses keeps the surface at an average temperature of 14 °C.[8] By photosynthesis, green plants convert solar energy into chemically stored energy, which produces food, wood and the biomass from which fossil fuels are derived.[9]

The total solar energy absorbed by Earth's atmosphere, oceans and land masses is approximately 3,850,000 exajoules (EJ) per year.[10] In 2002, this was more energy in one hour than the world used in one year.[11][12] Photosynthesis captures approximately 3,000 EJ per year in biomass.[13] The amount of solar energy reaching the surface of the



planet is so vast that in one year it is about twice as much as will ever be obtained from all of the Earth's non-renewable resources of coal, oil, natural gas, and mined uranium combined,[14]

Yearly solar fluxes & human consumption<sup>1</sup>

Solar 3,850,000 [10]

Wind 2,250 [15]

Biomass potential ~200 [16]

Primary energy use<sup>2</sup> 539 [17]

Electricity<sup>2</sup> ~67 [18]

<sup>1</sup> Energy given in Exa joule (EJ) =  $10^{18}$  J = 278 TWh

<sup>2</sup> Consumption as of year 2010

The potential solar energy that could be used by humans differs from the amount of solar energy present near the surface of the planet because factors such as geography, time variation, cloud cover, and the land available to humans limit the amount of solar energy that we can acquire.

Geography affects solar energy potential because areas that are closer to the equator have a greater amount of solar radiation. However, the use of photo voltaics that can follow the position of the sun can significantly increase the solar energy potential in areas that are farther from the equator.[4] Time variation effects the potential of solar energy because during the nighttime there is little solar radiation on the surface of the Earth for solar panels to absorb. This limits the amount of energy that solar panels can absorb in one day. Cloud cover can affect the potential of solar panels because clouds block incoming light from the sun and reduce the light available for solar cells.

In addition, land availability has a large effect on the available solar energy because solar panels can only be set up on land that is otherwise unused and suitable for solar panels. Roofs have been found to be a suitable place for solar cells, as many people have discovered that they can collect energy directly from their homes this way. Other areas that are suitable for solar cells are lands that are not being used for businesses where solar plants can be established.

Solar technologies are characterized as either passive or active depending on the way they capture, convert and distribute sunlight and enable solar energy to be harnessed at different levels around the world, mostly depending on distance from the equator. Although solar energy refers primarily to the use of solar radiation for practical ends, all renewable energies, other than Geo thermal power and Tidal power, derive their energy either directly or indirectly from the Sun.

Active solar techniques use photo voltaics, concentrated solar power, solar thermal collectors, pumps, and fans to convert sunlight into useful outputs. Passive solar techniques include selecting materials with favorable thermal properties, designing spaces that naturally circulate air, and referencing the position of a building to the Sun. Active solar technologies increase the supply of energy and are considered supply side technologies, while passive solar technologies reduce the need for alternate resources and are generally considered demand side technologies.

In 2000, the United Nations Development Program, UN Department of Economic and Social Affairs, and World Energy Council published an estimate of the potential solar energy that could be used by humans each year that took into account factors such as insolation, cloud cover, and the land that is usable by humans. The estimate found that solar

energy has a global potential of 1,575–49,837 EJ per year (see table below).

Annual solar energy potential by region (Exa joules)

Region	North America	Latin America and Caribbean	Western Europe	Central and Eastern Europe	Former Soviet Union	Middle East and North Africa	Sub-Saharan Africa	Pacific Asia	South Asia	Centrally planned Asia	Pacific OECD
Minimum	181.1	112.6	25.1	4.5	199.3	412.4	371.9	41.0	38.8	115.5	72.6
Maximum	7,410	3,385	914	154	8,655	11,060	9,528	994	1,339	4,135	2,263

### **1.9 Why is solar energy important?**

Solar energy is a potential solution to the environmental problems being caused by fossil fuels. When fossil fuels are burned to generate electricity, they release harmful greenhouse gases into the atmosphere. The vast majority of scientists believe that continuing to depend on fossil fuels is going to cause serious environmental problems in the future.

Another important use for solar energy is in satellites. Many satellites are engineered with photovoltaic panels, which capture sunlight and convert it into electricity that is used to power the satellite. Solar power is also useful in areas where standard electricity is not available. For example, research facilities in Antarctica depend on sustainable energy sources, such as the sun and wind turbines, to generate power.

Emergency phone systems in remote places often use solar power as a dependable power source. Solar energy can also be used to power devices that run at night. For example, some streetlights are able to

charge energy from the sun during the day, then run throughout the night.

### **1.10 Why Solar Power is a Reliable Long Term Investment?**

Solar Power is a Great Financial Investment in Many countries and certain degree of skepticism is normal with emerging technologies, and solar power is no exception. However, the benefits of solar PV systems are already being proven on a global scale, and there are strong reasons to believe in the technology. Warren Buffet, who is one of the richest businessmen in the world, has already invested several billion dollars on utility-scale photovoltaic projects. A notable example is the 2.5 billion dollar Topaz Solar Farm, in California.

The following are some of the main reasons why solar power is a reliable long term investment, which could become one of the mainstream energy sources in the short term.

### **1.11 Sunlight is Free and has Guaranteed Long-Term Availability**

Electric power technologies that depend on fossil fuels are subject to extreme price volatility. For example, the price of crude oil tends to fluctuate wildly from year to year – even the best economists are unable to predict with certainty how oil prices will behave. It might be tempting to invest on technology powered by fossil fuels when prices are low, but doing so can be a grave mistake:

- **Prices** - could rise again at any moment, and any company or country who is heavily dependent on fossil fuels will suddenly have to deal with considerable expenses. It has happened in the past it will happen again to those caught unaware.

· **Fossil fuels are a limited resource** – at current consumption rates, they will eventually be depleted. Some of the least favorable predictions state that the decline of fossil fuels will occur within the first half of this century.

**Solar power**, on the other hand, works with a reliable and predictable energy source. According to astronomers, the sun will last for five billion years more. If you want to find a technology with long-term availability, look no further: solar power is the answer. On top of that, sunlight is free: the only costs involved if you own a solar PV system are the initial investment and periodic maintenance.

**Installing a residential PV system** allows homeowners to reduce the impact of any electric energy price variation induced by the ups and downs of the fossil fuel market. The energy output of solar PV systems is guaranteed to be available for an investment that is known since the beginning.

### **1.12 What are the benefits of solar energy?**

Solar power is the the conversion of the energy from the sun to usable electricity. The most common source of solar power utilizes photovoltaic cells to convert sunlight into electricity. Photovoltaics utilize a semi-conductor to absorb the radiation from the sun, when the semi-conductor absorbs this radiation it emits electrons, which are harnessed as electricity.

### **1.13 Advantages of Solar**

Solar energy is a resource that is not only sustainable for energy consumption, it is indefinitely renewable (at least until the sun runs out in billions of years). Solar power can be used to generate electricity, it is also used in relatively simple technology to heat water (solar water heaters). The use of skylights in home construction can also greatly

reduce energy expenditure required to light rooms in a home interior during the day.

Solar panels also require little maintenance. After installation and optimization they are very reliable due to the fact that they actively create electricity in just a few millimeters and do not require any type of mechanical parts that can fail. Solar panels are also a silent producer of energy, a necessity if dealing with picky neighbors. The federal government has also introduced generous tax credits for individuals and companies that invest in solar and other clean energy systems.

#### **1.14 Solar Cell with Clouds Disadvantages of Solar**

The primary disadvantage of solar power is that it obviously cannot be created during the night. The power generated is also reduced during times of cloud cover (although energy is still produced on a cloudy day). Solar panel energy output is maximized when the panel is directly facing the sun. This means that panels in a fixed location, such as the building above, will see a reduced energy production when the sun is not at an optimal angle. Many large scale solar "farms" combat this problem by having the panels on towers (above left) that can track the sun to keep the panel at optimal angles throughout the day.

Even today most efficient solar cells only convert just over 20% of the sun rays to electricity. With increased advances in solar cell technology this number is likely to increase. Besides their low conversion efficiency, solar panels can be a substantial initial investment. However, the cost of solar panels incurred is only the initial cost, after buying and installation they create free energy for use.

## **Chapter 2**

### **2.1 Charge Controllers**

**Why a Charge Controller is necessary?**



Since the brighter the sunlight, the more voltage the solar cells produce, the excessive voltage could damage the batteries. A charge controller is

used to maintain the proper charging voltage on the batteries. As the input voltage from the solar array rises, the charge controller regulates the charge to the batteries preventing any overcharging.

## 2.2 Modern multi-stage charge controllers

Most quality charge controller units have what is known as a 3 stage charge cycle that goes like this:

1) **BULK**: During the Bulk phase of the charge cycle, the voltage gradually rises to the Bulk level (usually 14.4 to 14.6 volts) while the batteries draw maximum current. When Bulk level voltage is reached the absorption stage begins.

2) **ABSORPTION**: During this phase the voltage is maintained at Bulk voltage level for a specified time (usually an hour) while the current gradually tapers off as the batteries charge up.

3) **FLOAT**: After the absorption time passes the voltage is lowered to float level (usually 13.4 to 13.7 volts) and the batteries draw a small maintenance current until the next cycle.

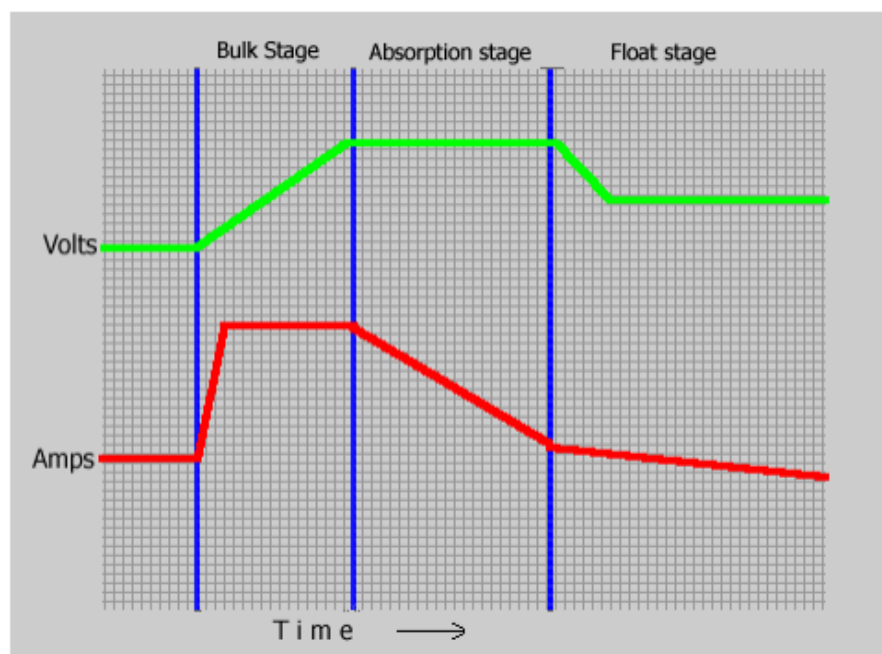



## **2.3 General Recommendations**

The following is a list of general recommendations to help the installer choose the right materials, equipment, and installation methods that will help ensure that the system will provide many years of reliable service.

These recommendations can be used to evaluate pre-engineered system designs and compare system features from one supplier to another.

## **2.4 Materials recommendations**

- Materials used outdoors should be sunlight/UV resistant
- Urethane sealants should be used for all non-flashed roof penetrations.
- Materials should be designed to withstand the temperatures to which they are exposed.
- Dissimilar metals (such as steel and aluminum) should be isolated from one another using non-conductive shims, washers, or other methods.
- Aluminum should not be placed in direct contact with concrete materials.
- Only high quality fasteners should be used (stainless steel is preferred).
- Structural members should be either:
  - . corrosion resistant aluminum, 6061 or 6063
  - . hot dip galvanized steel per ASTM A 123

- . coated or painted steel (only in low corrosive environments such as deserts)
- . stainless steel (particularly for corrosive marine environments)

## **2.5 Equipment recommendations and installation methods**

- All electrical equipment should be listed for the voltage and current ratings necessary for the application.
- PV modules should be listed to UL 1703 and warranted for a minimum of 5 years (20-25 year warranties are available).
- Inverters should be listed to UL 1741 and warranted for a minimum of 5 years (outside CA these may not be available).
- All exposed cables or conduits should be sunlight resistant.
- All required overcurrent protection should be included in the system and should be accessible for maintenance
- All electrical terminations should be fully tightened, secured, and strain relieved as appropriate.
- All mounting equipment should be installed according to manufacturers' specifications
- All roof penetrations should be sealed with an acceptable sealing method that does not adversely impact the roof warranty
- Integral roofing products should be properly rated (e.g., class A roofing materials)
- All cables, conduit, exposed conductors and electrical boxes should be secured and supported according to code requirements.

- PV Array should be free of shade between 9:00 a.m. and 4:00 p.m. This requirement includes even small obstructions such as vent pipes and chimneys. A small amount of shade can have a disproportionately high impact on system performance.

## 2.6 PV System Design And Installation

### Preparation Phase

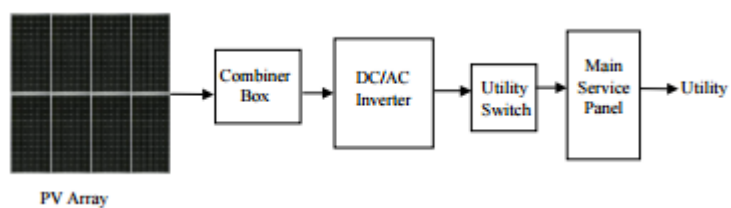

PV Array

DC/AC

Inverter

Combiner

Box

Main

Service

Panel

Utility Utility

Switch

## PV Installation Guide

1. Obtain past electric bills for the home if available and audit home to determine what can be done to reduce electricity usage.
2. Determine the size of the PV system based on budget, energy cost reduction, and available mounting area for the system. The PV system supplier typically provides the customer with sizing and performance information. The method in section 2 of this document is intended to provide a basis to identify those suppliers who are thorough in their sizing estimates.
3. Determine the physical size and dimensions of the PV array and its primary components. This is critically important in determining where the PV array and ancillary equipment is to be mounted.

### 2.7 Design Phase

1. Examine location options for mounting the PV array (i.e. roof, patio cover, other structure).
2. Review available pre-engineered system packages that contain the desired options. Compare the various product and system warranties available from each supplier.
3. Confirm that the PV equipment has the necessary listings required by building officials (e.g. UL 1703, UL 1741, and any applicable evaluation reports from National Evaluation Services (NES) or International Conference of Building Officials (ICBO) Evaluation Services)

4. Select system options making sure the equipment meets the guidelines of local incentive programs.
5. Contact local utility company (PG&E, SCE, or SDG&E) to obtain the required documents for interconnection and net metering.
6. Review documents to ensure system meets local interconnection requirements
7. Purchase the equipment.
8. Lay out PV array on roof plan or other structure. If roof mounted, determine required location of PV modules on roof and any potential roof penetrations due to plumbing or combustion appliance vents that could affect array placement or shade the array. Some obstructions can be relocated to another portion of the roof should the penetration dramatically impact the location of the array. Attempt to provide for an aesthetically pleasing layout by attempting to follow the dimensional shape of the roof section (example: if the roof is rectangular, try to maintain the same shape rectangle in the array layout). If modules are to be grouped in panels of several modules for ease of wiring and mounting, try to arrange the panels in symmetrical arrangements.
9. Calculate the impact of shading on the PV array layout with the assistance of a Solar Pathfinder). Consider other locations to mount the PV array if the proposed location receives too much shade. Review the mounting options discussed in section two of this guide for alternatives.
10. Measure the distance between the estimated locations of all system components and develop site drawing and one-line diagram of PV system installation for the permit package.
11. Assemble the permit package for the local authority having jurisdiction (AHJ). This package should include the following:
  - a. Site drawing showing the location of the main system components-- PV Array, conduit runs, electrical boxes, inverter enclosure, critical load

subpanel, utility disconnect, main service panel, and utility service entrance. (see drawing EX-1 in Appendix)

b. One-line diagram showing all significant electrical system components.

c. Cut sheets for all significant electrical system components (PV modules, inverter, combiner, dc-rated switches and fuses, etc...).

d. Copy of filled out utility contract.

e. Structural drawing if the system is incorporated into a separate structure.

f. Structural calculations as necessary

## **2.8 Installation Phase**

1. Submit required permit materials to the AHJ and pay for permit to begin construction.

2. Receive equipment and prepare for installation. Examine all equipment to be sure that all equipment was shipped and that none was damaged in shipping.

3. Review installation instructions for each component to become familiar with the installation process.

4. Estimate length of wire runs from PV modules to combiner and inverter.

5. Check ampacity of PV array circuits to determine the minimum wire size for current flow. Size wire for the run based on maximum short circuit current for each circuit and the length of the wire run.

Check ampacity of PV array circuits:

a. Minimum wire ampacity for the wire run from modules to combiner is based on module maximum series fuse rating printed on the listing label (i.e. 15-amps on 100-Watt module).

This is the minimum wire size and may need to be enlarged to reduce voltage drop.

b. Minimum wire ampacity for the wire run from combiner to inverter is based on the number of module series strings times the maximum series fuse rating (5 series strings = 5 x 15 amps = 75 amps). This is the minimum wire size and may need to be enlarged due to voltage drop.

6. Size PV array wiring such that the maximum voltage drop at full power from the PV modules to the inverter is 3% or less (6-amps for a 100-Watt module). If array combiner box is located remote from the inverter, spread the voltage drop accordingly between the PV array-to-combiner wiring and the combiner-to-inverter wiring (example from EX-1 in the appendix: with a 100-foot wire run from PV modules to inverter (3% total) comprised of a 25-foot wire run from PV modules to combiner box and a 75-foot wire run from combiner box to inverter—use a maximum of 1% for the 25-foot run and 2% loss for the 75-foot section for a total of 3%)

a. wire run from modules to combiner is 25 feet.

b. wire run from combiner to inverter is 75 feet.

7. Estimate length of wire run from inverter to main service panel.

8. Examine main service panel to determine if the panel is adequately sized to receive the PV breaker or whether the panel must be upgraded.

Many homes in certain developed parts of the region are fed by a 100-amp service panel. For residential applications, the NEC 690-64 allows the total supply (utility plus PV) to the bus bar of the service panel to equal 120% of the bus bar rating (100-amps x 1.2 = 120-amps). This means that a 100-amp service panel can have a 100-amp main breaker and a 20-amp PV breaker. If our example system can supply 45-amps of continuous power, we need room for a 60-amp circuit breaker (45-amps

x 1.25 = 56.25 amps). A system that size will require either replacing the 100-amp main breaker with a 75-amp unit (not usually recommended) or replacing the existing 100-amp service panel with a 200-amp service panel. The 200-amp service panel is allowed 240-amps of supply (200-amps x 1.2= 240-amps) so if the PV breaker is rated at 60-amps, the main breaker can be up to 180 amps (240 amps – 60 amps = 180 amps)

9. If system includes a critical load subpanel (battery standby system), determine which circuits are critical. These circuits must be adequately designed to handle the anticipated electrical loads. The standby portion of the system is considered by the NEC to be an Optional Standby System covered by Article 702.

a. Warning: Multi-wire branch circuits in a home must be closely evaluated to allow them to be wired to a 120VAC optional standby system. There are four main ways to deal with these types of circuits:

i. Install an autotransformer on the output of the inverter to step up the supplied voltage from 120Vac to 240Vac if necessary. The critical load subpanel can then be powered without concern of neutral overload.

ii. Rerun one new branch circuit with each multiwire circuit so that one of the supply conductors of the multiwire circuit can be eliminated and the two circuits no longer share the neutral.

iii. Avoid multiwire branch circuits in the home. This is often unacceptable since refrigerators and other key loads are normally found on multiwire branch circuits.

iv. Derate the supply breaker to match the ampacity of the neutral wire. This is done by first determining that the maximum load on the two circuits is less than 80% of the rating of one pole of the double-pole supply breaker. For instance, if the supply breaker is a 20-amp double-pole breaker, the maximum allowable load on both circuits is a total of 16-amps at 120-Vac. To confirm this load, turn on all the loads intended to be operated at the same time and measure the load current with a clamp-on ammeter. If the total from the two circuits is less than 16-



amps, the circuit may be supplied by a single-pole 20-amp circuit breaker, which protects the neutral from overload.

b. All loads to be connected to the optional standby system must be carefully evaluated to determine if the actual power consumption and daily usage for each load can be met by the system in standby mode.

c. All standby loads must be wired into a separate sub-panel for connection to the standby output of the inverter.

d. Average power consumption for the standby power system loads must be calculated to determine how long the storage battery will provide uninterrupted power for typical electric usage.

e. Article 702--Optional Standby Systems allows sizing based on supply of all equipment intended to be operated at one time (NEC 702-5). This means that all the 120-Volt loads could be run off of a single-pole 60-amp breaker from an optional standby system as long as the actual continuous load is below the 80% limit for continuous operation of a breaker (48 amps).

f. It is recommended that the storage battery system consist of maintenance-free valve regulated lead-acid (VRLA) batteries with absorbed glass mat (AGM) construction since these require no maintenance by the homeowner. Other types of batteries may become available in the future that are equally suited to this application, but do not attempt to use any battery that has not been thoroughly tested in Uninterruptible Power System (UPS) applications.

g. Battery storage cabinet must be kept out of the sun and in as cool a place as practical.

h. Every battery storage system, whether it includes flooded lead acid, or valve-regulated lead acid batteries, requires ventilation. Battery storage cabinet must be ventilated to the outdoors; vents need to be at the high and low points in the cabinet. For battery systems in utility rooms in a living space, follow the same ventilation requirements as needed for gas fired service water heaters.

10. Determine location of critical load subpanel, install subpanel and prepare to move circuits
11. Install PV array. Packaged systems should include detailed instructions on each phase of the installation process. Some basic guidelines that may help in reviewing installation procedures are:
  - a. Prepare structure for mounting of PV array. If roof-mounted, hire roofing contractor to install roof mounts according to manufacturer's directions.
  - b. Check modules visually and check the open circuit voltage and short circuit current of each module before hauling onto the structure to verify proper operation—see checklist.
  - c. Use plug connectors to connect panels together where listed products are available. This reduces installation time.
  - d. Use only as many attachment points and roof penetrations as necessary for structural loading concerns. The number of attachment points and structural requirements of the roof must be specifically identified in the drawings.
  - e. Mount PV array to support structure.
12. Install PV combiner, inverter, and associated equipment to prepare for system wiring.
13. Connect properly sized wire (determined in step 6 of installation phase) to each circuit of modules and run wire for each circuit to the circuit combiner(s). (WARNING: It is advisable to terminate the circuits in the circuit combiner prior to completing the final connection for each string at the PV array end of the circuit.)
14. Run properly sized wire (determined in step 6 of installation phase) from circuit combiner to inverter overcurrent/disconnect switch (if available--follow installation procedure supplied by manufacturer).
15. Run properly sized wire (determined in step 7 of installation phase) from inverter to utility disconnect switch (WARNING: Make sure the

neutral wire does not get routed through one of the switch poles in the disconnect box.)

16. Run properly sized wire (determined in step 7 of installation phase) from utility disconnect switch to main service panel and connect circuit to the main utility service.

17. Use the checklist in section 4 to ensure proper installation throughout the system.

18. Verify that all PV circuits are operating properly and the system is performing as expected. The PV

System Installation Checklist in section 4 of this guide has a detailed performance testing procedure entitled System Acceptance Test.

19. Shut system down and call for final inspections (AHJ first then utility-if necessary).

20. Once approval to parallel is received from the utility, begin system operation.

21. Enjoy watching your meter spin backward. (note: Time-Of-Use net meters do not have a meter disk to watch run backward—it has a digital readout instead).

## **2.9 Maintenance and Operation Phase**

1. Wash PV array, during the cool of the day, when there is a noticeable buildup of soiling deposits.

2. Periodically inspect the system to make sure all wiring and supports stay intact.

3. On a sunny day near noon on March 21 and September 21 of each year, review the output of the system (assuming the array is clean) to see if the performance of the system is close to the previous year's reading. Maintain a log of these readings so you can identify if the

system is performance is staying consistent, or declining too rapidly, signifying a system problem.

## **2.10 SOLAR ELECTRIC (PV) SYSTEM INSTALLATION CHECKLIST**

Following the completion of each item on the checklist below, check the box to the left of the item and insert the date and initials of the person completing the item whether that is the installing contractor or owner-installer. Remember to follow the proper safety procedures while performing the system installation. The appropriate safety equipment for each section of the checklist is listed above each section of the checklist.

Before starting any PV system testing: (hard hat and eye protection recommended)

1. Check that non-current carrying metal parts are grounded properly. (array frames, racks, metal boxes, etc. are connected to the grounding system)
2. Ensure that all labels and safety signs specified in the plans are in place.
3. Verify that all disconnect switches (from the main AC disconnect all the way through to the combiner fuse switches) are in the open position and tag each box with a warning sign to signify that work on the PV system is in progress.

PV ARRAY--General (hard hat, gloves, and eye protection recommended)

1. Verify that all combiner fuses are removed and that no voltage is present at the output of the combiner box.
2. Visually inspect any plug and receptacle connectors between the modules and panels to ensure they are fully engaged.

3. Check that strain reliefs/cable clamps are properly installed on all cables and cords by pulling on cables to verify.
4. Check to make sure all panels are attached properly to their mounting brackets and nothing catches the eye as being abnormal or misaligned.
5. Visually inspect the array for cracked modules.
6. Check to see that all wiring is neat and well supported.

### **2.11 PV ARRAY CIRCUIT WIRING (hard hat and eye protection recommended)**

1. Check home run wires (from PV modules to combiner box) at DC string combiner box to ensure there is no voltage on them.
2. Recheck that fuses are removed and all switches are open.
3. Connect the home run wires to the DC string combiner box terminals in the proper order and make sure labeling is clearly visible.

### **2.12 REPETITIVE SOURCE CIRCUIT STRING WIRING (hard hat, gloves, and eye protection recommended)**

The following procedure must be followed for each source circuit string in a systematic approach—i.e. east to west or north to south. Ideal testing conditions are midday on cloudless days March through October.

4. Check open-circuit voltage of each of the panels in the string being wired to verify that it provides the manufacturer's specified voltage in

full sun. (Panels under the same sunlight conditions should have similar voltages--beware of a 20 Volt or more shift under the same sunlight conditions.)

5. Verify that the both the positive and negative string connectors are identified properly with permanent wire marking.
6. Repeat this sequence for all source circuit strings.

### **2.13 CONTINUATION OF PV ARRAY CIRCUIT WIRING (hard hat, gloves, and eye protection recommended)**

7. Recheck that DC Disconnect switch is open and tag is still intact.
8. VERIFY POLARITY OF EACH SOURCE CIRCUIT STRING in the DC String Combiner

Box (place common lead on the negative grounding block and the positive on each string connection-pay particular attention to make sure there is NEVER a negative measurement). Verify open-circuit voltage is within proper range according to manufacturer's installation manual and number each string and note string position on as-built drawing. (Voltages should match closely if sunlight is consistent.)

**WARNING: IF POLARITY OF ONE SOURCE CIRCUIT STRING IS REVERSED, THIS CAN START A FIRE IN**

**THE FUSE BLOCK RESULTING IN THE DESTRUCTION OF THE COMBINER BOX AND POSSIBLY**

**ADJACENT EQUIPMENT. REVERSE POLARITY ON AN INVERTER CAN ALSO CAUSE DAMAGE THAT IS NOT COVERED UNDER THE EQUIPMENT WARRANTY.**

9. Retighten all terminals in the DC String Combiner Box.

## **2.14 WIRING TESTS--Remainder of System: (hard hat, gloves, and eye protection recommended)**

10. Verify that the only place where the AC neutral is grounded is at the main service panel.
11. Check the AC line voltage at main AC disconnect is within proper limits (115-125 Volts AC for 120 Volts and 230-250 for 240 Volts).
12. If installation contains additional AC disconnect switches repeat the step 11 voltage check on each switch working from the main service entrance to the inverter AC disconnect switch closing each switch after the test is made except for the final switch before the inverter (it is possible that the system only has a single AC switch).

## **2.15 INVERTER STARTUP TESTS (hard hat, gloves, and eye protection recommended)**

1. Be sure that the inverter is off before proceeding with this section.
2. Test the continuity of all DC fuses to be installed in the DC string combiner box, install all string fuses, and close fused switches in combiner box.
3. Check open circuit voltage at DC disconnect switch to ensure it is within proper limits according to the manufacturer's installation manual.
4. If installation contains additional DC disconnect switches repeat the step 4 voltage check on each switch working from the PV array to the inverter DC disconnect switch closing each switch after the test is made except for the final switch before the inverter (it is possible that the system only has a single DC switch).

5. At this point consult the inverter manual and follow proper startup procedure (all power to the inverter should be off at this time).
6. Confirm that the inverter is operating and record the DC operating voltage in the following space. \_\_\_\_\_
7. Confirm that the operating voltage is within proper limits according to the manufacturer's installation manual.
8. After recording the operating voltage at the inverter close any open boxes related to the inverter system.
9. Confirm that the inverter is producing the expected power output on the supplied meter.
10. Provide the homeowner with the initial startup test report.

## **2.16 SYSTEM ACCEPTANCE TEST (hard hat and eye protection recommended)**

Ideal testing conditions are midday on cloudless days March through October. However, this test procedure accounts for less than ideal conditions and allows acceptance tests to be conducted on sunny winter days.

1. Check to make sure that the PV array is in full sun with no shading whatsoever. If it is impossible to find a time during the day when the whole array is in full sun, only that portion that is in full sun will be able to be accepted.

‰

2. If the system is not operating, turn the system on and allow it to run for 15 minutes before taking any performance measurements.

‰



3. Obtain solar irradiance measurement by one of two methods and record irradiance on this line: W/m<sup>2</sup>

. To obtain percentage of peak sun, divide irradiance by 1000 W/m<sup>2</sup> and record the value on this line . (example: 692 W/m<sup>2</sup> ÷ 1000 W/m<sup>2</sup> = 0.692 or 69.2%.)

**Method 1:** Take measurement from calibrated solar meter or pyranometer.

**Method 2:** Place a single, properly operating PV module, of the same model found in the array, in full sun in the exact same orientation as the array being tested. After 15 minutes of full exposure, test the short circuit current with a digital multi meter and place that reading on this line: Amps. Divide this number into the short circuit current (I<sub>sc</sub>) value printed on the back of the PV module and multiply this number by 1000 W/m<sup>2</sup> and record the value on the line above. (example : I<sub>sc</sub>-measured = 3.6 Amps;

I<sub>sc</sub>-printed on module = 5.2 Amps; Irradiance = 3.6 Amps/5.2 Amps \* 1000 W/m<sup>2</sup> = 692 W/m<sup>2</sup>)

4. Sum the total of the module ratings and place that total on this line Watts STC.

Multiply this number by 0.7 to obtain expected peak AC output and record on this line Watts AC -estimated.

5. Record AC Watt output from the inverter or system meter and record on this line

Watts AC- measured.

6. Divide Watts AC-measured by percent peak irradiance and record on this line Watts AC-corrected. This “AC-corrected” value is the rated output of PV system. This number must be within 90% or higher of Watts AC-estimated recorded in step 4. If it is less than 90%, the PV system is either shaded, dirty, miswired, fuses are blown, or the modules or inverter are not operating properly.

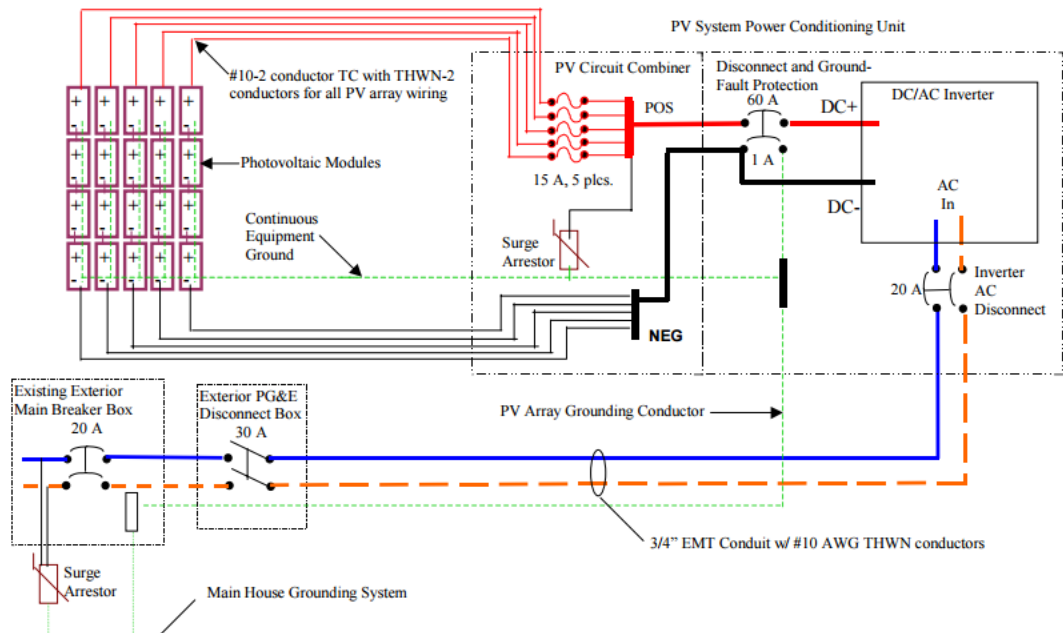
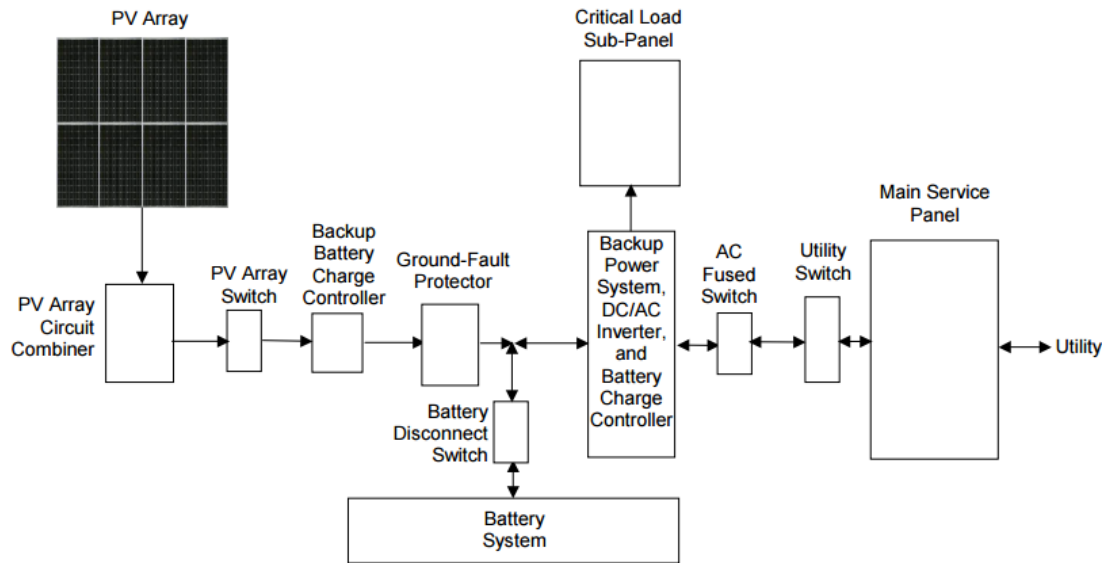

## **Chapter 3: Consumption**

### **3.1 Power consumption Table**

These figures are approximate representations. The actual power consumption of your appliances may vary substantially from these figures. Check the power tags, or better yet, measure the amperage draw with a clamp-on ammeter. Multiply the hours used on the average day by the wattage listed below. This will give you the watt hours consumed per day.

Remember that some items, such as garage door openers, are used only for a fraction of an hour or minute per day. A 300 watt item used for 5 minutes per day will only consume 25 watt hours per day where a range of numbers are given, the lower figure often denotes a technologically newer and more efficient model. The letters "NA" denote appliances which would normally be powered by non-electric sources in a PV powered home.

We strongly suggest that you invest in a true RMS digital multimeter if you are considering making your own power. Also helpful are clamp-on type ammeters. It actually makes sense to know where your power is being used, even if you are not producing it, and if you are, these meters are essential diagnostic tools.

appliance	watts	appliance	watts	appliance	watts
Coffee Pot	200	Garage door opener	350	Compact fluorescent	
Coffee Maker	800	Ceiling fan	10-50	Incandescent equivalents	
Toaster	800-1500	Table fan	10-25	40 watt equivalent	11
Popcorn Popper	250	Electric blanket	200	60 watt equivalent	16
Blender	300	Blow dryer	1000	75 watt equivalent	20
Microwave	600-1500	Shaver	15	100 watt equivalent	30
Waffle Iron	1200	Waterpik	100		
Hot Plate	1200	Well Pump (1/3-1 HP)	480-1200	Electric mower	1500
Frying Pan	1200			Hedge trimmer	450
		Computer		Weed eater	500
Dishwasher	1200-1500	Laptop	20-50	1/4" drill	250
Sink waste disposal	450	PC	80-150	1/2" drill	750
		Printer	100	1" drill	1000
Washing machine		Typewriter	80-200	9" disc sander	1200
Automatic	500	Television		3" belt sander	1000
Manual	300	25" color	150	12" chain saw	1100
Vacuum cleaner		19" color	70	14" band saw	1100
Upright	200-700	12" black and white	20	7-1/4" circular saw	900
Hand	100	VCR	40	8-1/4" circular saw	1400
Sewing machine	100	CD player	35		
Iron	1000	Stereo	10-30	Refrigerator/Freezer	
		Clock radio	1	20 cu. ft. (AC)	1411 watt-hours/day*
Clothes dryer		AM/FM auto cassette player	8	16 cu. ft. (AC)	1200 watt-hours/day*
Electric NA	4000	Satellite dish	30		
Gas heated	300-400	CB radio	5	Freezer	
		Electric clock	3	15 cu. ft. (Upright)	1240 watt-hours/day*
Heater				15 cu. ft. (Chest)	1080 watt-hours/day*
Engine block NA	150-1000	Radiotelephone			
Portable NA	1500	Receive	5		
Waterbed NA	400	Transmit	40-150		
Stock tank NA	100				
Furnace blower	300-1000	Lights:		Note: TV's, VCR's and other devices left	
Air conditioner NA		100 watt incandescent	100	plugged in, but not turned on, still	
Room	1000	25 watt compact fluor.	28	draw power.	
Central	2000-5000	50 watt DC incandescent	50		
		40 watt DC halogen	40		
		20 watt DC compact fluor.	22		

By avoiding indoor air pollution caused by kerosene lanterns, a solar light reduces coughing, flu-like symptoms, eye irritation and respiratory illness. The harms from kerosene lamps kill over four million people each year. UNICEF's recent predictions for 2030 show that indoor air pollution will cause more premature deaths than HIV and malaria combined.

SolarAid's work in Africa has helped 2.2 million people, who switched to solar, experience improvements in their health.

## How fast energy efficiency is improving in the household sector?

Odyssey energy efficiency index (ODEX) (EU-27)

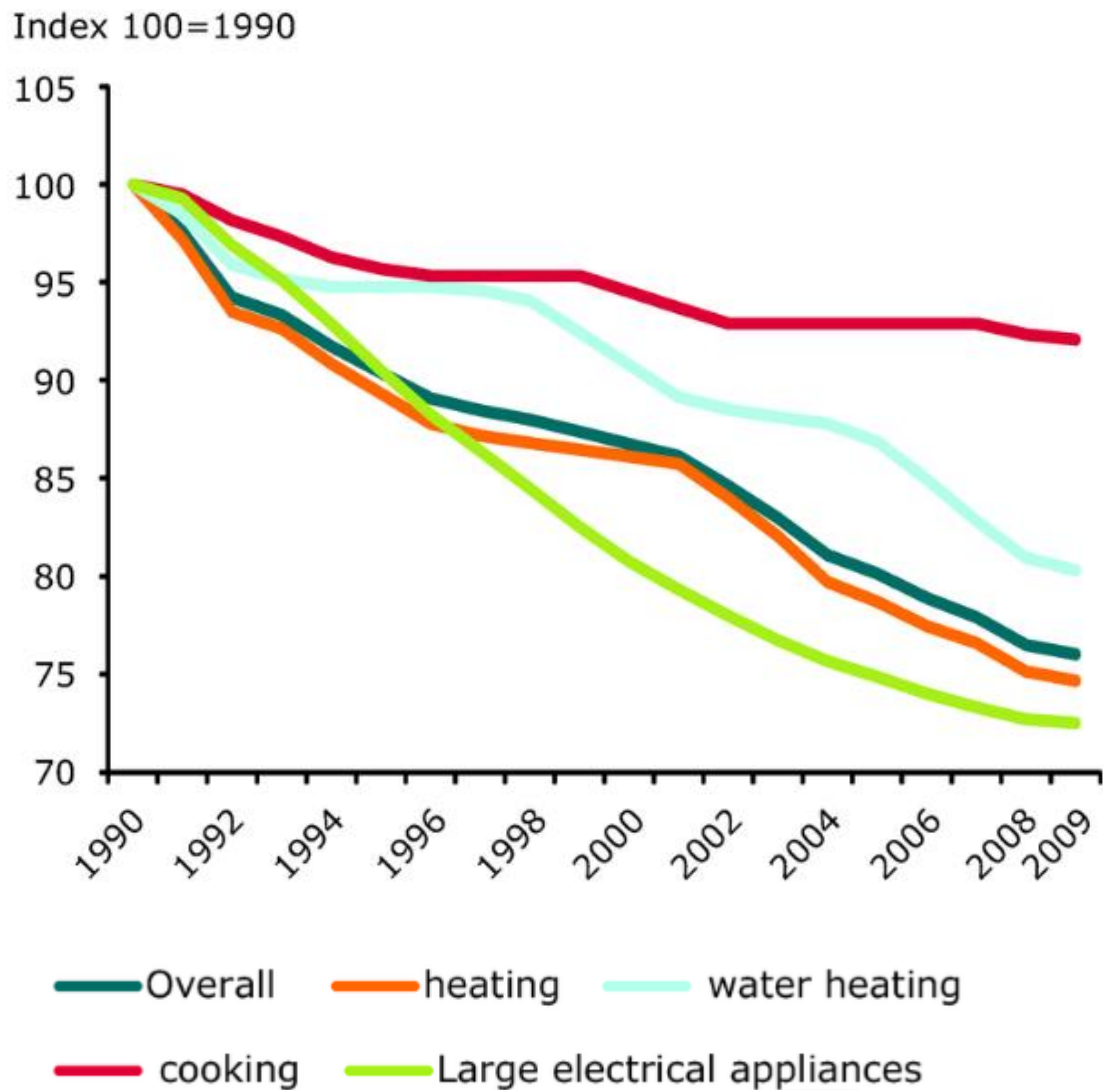

### **3.2 THE ECONOMICS OF A SMALL SOLAR ELECTRIC SYSTEM**

The economics of a home solar electric or PV system are determined by both the capital and operating costs. Capital costs include the initial costs of designing and installing a PV system. Operating costs include the costs associated with maintaining and operating the PV system over its useful life.

The factors that affect both capital and operating costs include:

System components

System size

Whether a system is grid-connected or stands alone (off-grid)

Solar resource at your location (amount of sunlight).

### **3.3 ELECTRICITY CONSUMPTION**

Before selecting system components and sizing a PV system for an existing home, you should evaluate your energy consumption patterns and try to reduce your home's electricity use. You can start by performing a load analysis, which includes these tasks:

Looking at your utility bills over the past year

Calculating energy consumption

Recognizing consumption trends.

By understanding your "energy habits" and becoming more energy efficient, you can reduce the size of the PV system you'll need, lowering both your capital and operating costs.

If you're designing a new home, you should work with the builder and the solar professional to incorporate your PV system into your whole-house system design -- an approach for building an energy-efficient home.

### **3.4 PV COST CONSIDERATIONS**

Ask your PV provider how much electricity your new PV system will produce per year (measured in kilowatt-hours) and compare that number to your annual electricity usage (called demand) to get an idea of how much you will save. As a rule, the cost per kilowatt-hour goes down as you increase the size of the system.

You should also compare the purchase price of utility-generated electricity to the higher costs of smaller PV systems. PV-generated

electricity is usually more expensive than conventional, utility-supplied electricity. However, these costs will vary by geographic location.

Solar rebate programs, subsidies, and other incentives can help make PV more affordable. Tax incentives may include a sales tax exemption on the PV system purchase, a property tax exemption, or state personal income tax credits, all of which provide an economic benefit to consumers by lowering high capital costs.

Some solar rebate programs are capped at a certain dollar amount. Therefore, a solar electric system that matches this cap maximizes the benefit of the solar rebate.

Many homeowners use PV systems because other considerations - - such as environmental benefits and energy independence -- tip the balance in their favor.

### **3.5 PERMITS AND COVENANTS**

Before purchasing a home solar electric system, research your local permit and neighborhood covenant requirements.

You will probably need to obtain permits from your city or county building department. These include a building permit, an electrical permit, or both. Typically, your PV provider will take care of this, rolling the price of the permits into the overall system price. However, in some cases, your PV provider may not know how much time or money will be involved in obtaining a permit. If so, this task may be priced on a time-and-materials basis, particularly if additional drawings or calculations must be provided to the permitting agency. In any case, make sure the permitting costs and responsibilities are addressed at the start with your PV provider before installation begins.

Code requirements for PV systems vary somewhat from one jurisdiction to the next, but most are based on the National Electrical Code (NEC). Article 690 in the NEC spells out requirements for designing and installing safe, reliable, code-compliant PV systems.

If you are one of the first people in your community to install a PV system, your local building department may not have experience in approving one of these systems. If this is the case, you and your PV provider can speed up the process by working closely with building officials to educate them on the technology.

If you live where a homeowners association must approve a solar electric system, you or your PV provider will likely need to submit your plans and get approval before you begin installing your PV system. However, some state laws stipulate that you have the right to install a solar electric system on your home.

For more information on state and community codes and requirements, see [planning for a small renewable energy system](#).

### **3.6 STAND-ALONE SMALL SOLAR ELECTRIC SYSTEMS**

A stand-alone home solar electric or PV system operates "off-grid" -- it isn't connected to an electricity distribution grid operated by a utility.

A stand-alone PV system makes sense if any of the following apply:

You live in a remote location where the system would be more cost effective than extending a power line to a grid.

You're considering a hybrid electric system -- one that uses both a PV system and a small wind electric system.



You need minimal amounts of power; e.g., irrigation control equipment and remote sensors.

Anyone can take advantage of outdoor solar lighting -- a stand-alone PV application.

For more information, see Stand-Alone Home Energy Systems.

A grid-connected home solar electric or PV system receives back-up power from a utility's grid when the PV system is not producing enough power. When the system produces excess power, the utility is required to purchase the power through a metering and rate arrangement.

Net metering is the best arrangement. Under this arrangement, the power provider essentially pays you retail price for the electricity you feed back into the grid.

For more information, see Grid-Connected Home Energy Systems.

Using the equation below, you can estimate the annual electricity production and electric bill savings for a grid-connected home solar electric system with a net metering arrangement.

Determine the PV system's size in kilowatts (kW). A typical range is from 1 to 5 kW. This value is the "kW of PV" input for the equation below.

Based on your geographic location, select the energy production factor from the map below for the "kWh/kW-year" input for the following equation.

Electricity production from the PV system = (kW of PV) × (kWh/kW-year)  
= kWh/year

You can calculate your annual electric bill savings using the following equation. Note that the residential rate should be in dollars per kWh; for example, a rate of 10 cents per kWh is input as \$0.10/kWh.

Electric bill savings = (kWh/year) × (Residential Rate) = \$/year

(To determine your monthly electric bill savings, divide the final number above by 12.)

For example, a 2-kW system in Denver, CO, at a residential energy rate of 7 cents/kWh will save about \$266 per year:  $2 \text{ kW} \times 1,900 \text{ kWh/kW-year} \times \$0.07/\text{kWh} = \$266/\text{year}$  (or \$22.17/month).

## Chapter 4: Self-consumption and Summary

The self-consumption of solar energy refers to the proportion of energy which is used directly in the building where a PV system is located. When a photovoltaic array on a building produces electricity and this electricity is used to power a washing machine, for example, this is referred to as self-consumption. It's important that the electricity needed for internal use is neither fed into nor drawn from the public grid.

Self-consumption pays off twice! First of all, the amount of energy consumed is subsidized by the state. And secondly, using energy that you have generated yourself reduces the amount of energy that you need to purchase from your power company.



## 4.1 Natural: Self-consumption

Every household uses energy on a daily basis. The amount of electricity used varies over the course of the day, from season to season and, of course, when the weather changes. At the same time, the energy supplied by photovoltaic systems also fluctuates over the course of a day, at different times of year and depending on the weather conditions.

Self-consumption is calculated as the ratio of directly consumed energy to generated energy. Natural self-consumption is a statistical value. It indicates the proportion of solar power generated by a photovoltaic system with a specific output that a household of a certain size can use without conscious changes in behavior or the use of technical components.

The natural self-consumption rate is usually about 20% for a one-person household and about 40% for a five person household and a 5 kWp system.

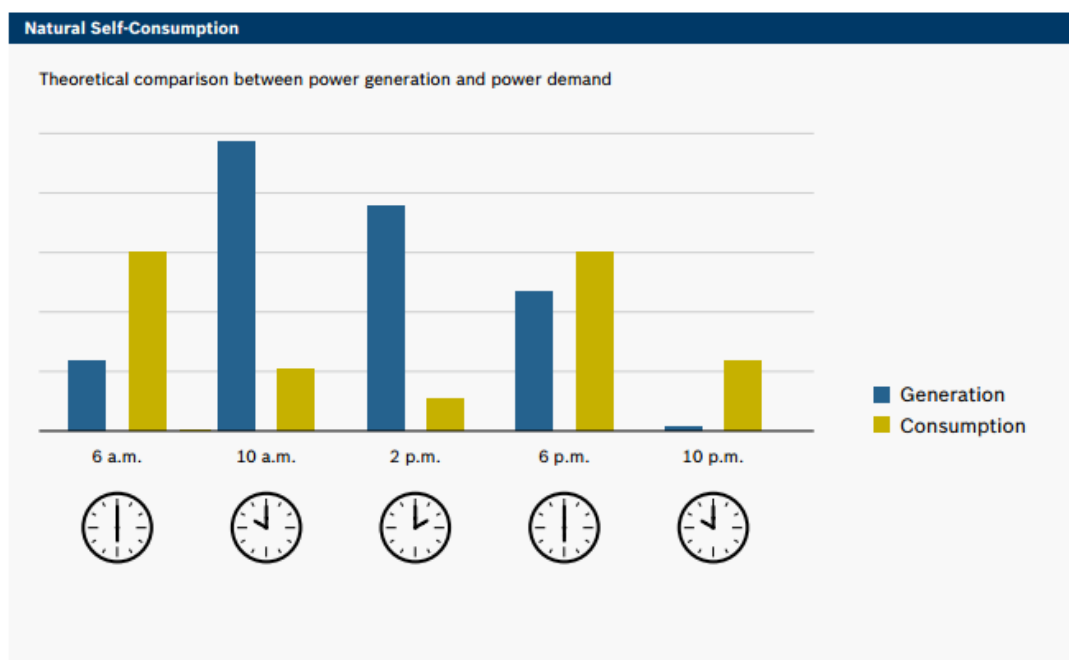

## 4.2 Optimized Self-Consumption, Generation Consumption

Self-consumption quotas can be increased by implementing simple optimization measures.

Either by changing user behavior (manual optimization):

-Scheduling the use of household appliances, such as the washing machine, drier and dishwasher, at times when the sun produces the most energy or, with specially designed technical

### solutions:

-Intelligent household appliance controls

-Appliances with time delay functions

-Appliances which store energy themselves for automatic use at a later time. This technology should be possible in the future with new types of batteries (electricity storage) and materials (storage of heat /cold).

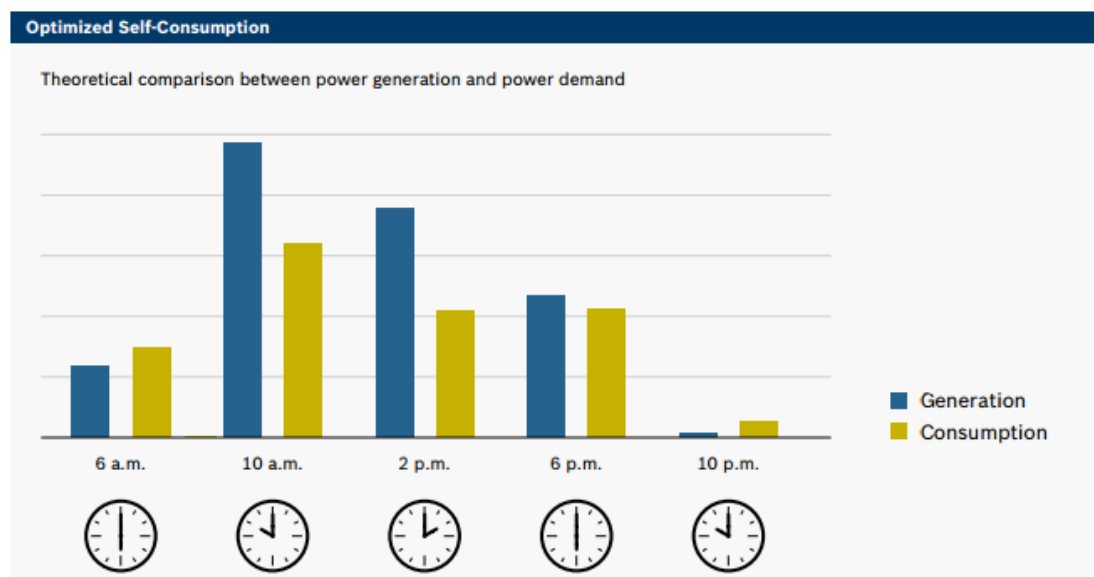

### **4.3 Self-consumption pays off!**

Sinking feed-in tariffs combined with steadily rising energy costs are making self-consumption key factor for the economic feasibility of a photovoltaic system. It is becoming more and more important for customers to be able to use as much of their own self-generated solar energy as possible.

#### **► Independence**

With solar energy generated by a photovoltaic system, you can become your own electric company. The use of self-generated solar energy not only makes you less dependent on commercial energy suppliers, but also helps reduce our reliance on conventionally produced energy from fossil fuels or nuclear power.

#### **► Savings Potential**

By using solar energy that you have generated yourself, you can reduce the amount of electricity that you need to "buy" from the public grid. This helps reduce your electricity bill on a regular basis. Plus, you'll save even more money every time the electric companies raise their prices because you can always use the electricity you have generated yourself for free.

#### **► Security for the Future**

With high-performance solar modules from Bosch Solar Energy, anyone can generate and use electricity safely and with long-term security. As a well-established company with a successful history stretching back over more than 125 years, Bosch is a truly reliable business partner. Plus, having your own photovoltaic system reduces your household's CO<sub>2</sub> balance and contributes to the move toward environmentally-friendly sustainable alternative energy sources that can help secure a better environment for us all.

#### ► Increased Cost Savings Effect

Intelligent storage solutions designed for time-delayed power consumption are becoming more and more important as they enable the most efficient internal use of self-generated solar energy. Self-collected solar energy can thus be used even when the sun is not shining. This increases the percentage of self-generated energy that you can use yourself and only the energy that you do not need is then fed into the public grid at the current feed-in tariff.

### **4.4 A Brief Summary**

Reliance on fossil fuels brings many problems, from damage to the Earth to pollution of the atmosphere and waters. Solar energy offers power without the need to burn fossil fuels. In its basic form, it needs no distribution grid because it comes down from the sky. It's under intensive development as a source of electric power, but sometimes its applications can be much smaller and simpler.

#### **Solar Energy Offers Many Benefits**

Solar energy offers clean power. It doesn't present the risk of a nuclear spill, but it is in fact a release of radiation, only some of which is visible light. It can be scaled to any size or complexity, from warming a room through a window to powering a utility grid.

The Union of Concerned Scientists lists numerous benefits, beginning with solar energy being inexhaustible and free. The attractiveness of solar power production varies with the economics of investing in equipment, and cost competition from fossil fuels. Scientific American estimates the cost of solar power falling below the current average power cost by 2018 or 2020.

## **Common Ways to Harvest Solar Energy**

Solar radiant heat is easily captured by simple glass greenhouses, and through residential windows. "Concentrated" solar energy uses huge arrays of mirrors to focus sunlight on a central tower, which heats water to generate steam that can be used to generate electricity.

Photovoltaic (PV) cells convert sunlight directly to electricity through the photoelectric effect. NASA describes how the silicon semiconductors in the cells capture energy from sunlight's photons, which dislodge electrons in the semiconductor, creating a current. Groups of cells form modules, and modules combine into larger arrays. These can be configured to produce any combination of voltage and current.

## **Large-Scale and Small-Scale Solar Energy Applications**

The U.S. Energy Information Administration defines "utility-scale" solar plants as those generating at least one megawatt of electricity. California leads the United States in solar energy production; in 2013, 1.9 percent of California's power came from solar, and by 2014, the number more than doubled to 5 percent. The U.S. EIA puts the country's production of photovoltaic solar power at 16,000 megawatthours (MWh) in 2005, and rising to 15,874,000 MWh in 2014. Small-scale applications of solar power also prove useful, like the 5-watt units installed on Ohio Highway Patrol cruisers to power on-board electronic equipment without needing to run the car's engine, thus saving fossil fuel and battery life.

## **A Variety of Solar Power Uses**

The United Nations estimates that in many climates, residential solar thermal systems can supply 50 to 75 percent of a household's hot water needs. Small stand-alone PV units can power roadside warning signs or even landscape lighting, but since they're off the grid, they need batteries to store power when sunlight isn't available. Residential solar



power arrays typically connect to the grid as a backup, and they have the benefit of allowing the owner to sell excess power, depending on local power provider regulations.

## **Chapter 5: Conclusion**

To conclude, interested parties should understand that, if the power supply is based exclusively on a standalone photovoltaic system, they should reduce their electricity needs to the fullest extent possible. The engineer alternatives must offer them in terms of the use of devices that can be replaced by others that do not require electricity, where possible, in order to pick up an end while satisfying decision as to the size of the installation.

Today, the autonomous photovoltaic systems find application in a few cases by the lack of reliability and hefty amount of money to be spent on the design and installation. Usually, we meet in homes remote from the power grid or cottages inhabited mainly during the summer months and the energy requirements and this storage is very limited.

Since fossil fuels are some limits exist and will eventually run out, the technology has already shifted to renewable energy sources focusing on solar. This is very encouraging because PV technology will develop in the future could become the main power supply of human resource.

## **Context**

- 1 Planning and Installing Photovoltaic Systems- A guide for installers, architects and engineers, second edition, Earth scan.
2. Stand - Alone Photovoltaic Systems handbook of recommended design practices, Sandia National Laboratories, 1995
3. wikipedia
4. European Environment Agency.
5. Renewable and Efficient Electric Power Systems», Gilbert M. Masters
6. «Photovoltaic Systems, Klaus Preiser
7. Stand Alone PV System Design
8. Batteries and charge control in stand - alone photovoltaic systems, James P. Dunlop, Florida energy center, 1997
9. bosch-solarenergy.com
10. Energy.gov
11. [www.energy-community.org](http://www.energy-community.org)
12. sciencing.com